

marantz®

Model CD-17mkII User Guide

Compact Disc Player



ENGLISH

WARRANTY

For warranty information, contact your local Marantz distributor.

RETAIN YOUR PURCHASE RECEIPT

Your purchase receipt is your permanent record of a valuable purchase. It should be kept in a safe place to be referred to as necessary for insurance purposes of when corresponding with Marantz.

IMPORTANT

When seeking warranty service, it is the responsibility of the consumer to establish proof and date of purchase. Your purchase receipt or invoice is adequate for such proof.

FOR U.K. ONLY

This undertaking is in addition to a consumer's statutory rights and does not affect those rights in any way.

FRANÇAIS

GARANTIE

Pour des informations sur la garantie, contacter le distributeur local Marantz.

CONSERVER L'ATTESTATION D'ACHAT

L'attestation d'achat est la preuve permanente d'un achat de valeur. La conserver en lieu sûr pour s'y reporter aux fins d'obtention d'une couverture d'assurance ou dans le cadre de correspondances avec Marantz.

IMPORTANT

Pour l'obtention d'un service couvert par la garantie, il incombe au client d'établir la preuve de l'achat et d'en corroborer la date. Le reçu ou la facture constituent des preuves suffisantes.

DEUTSCH

GRANTIE

Bei Garantiefragen wenden Sie sich bitte an Ihren Marantz-Händler.

HEBEN SIE IHRE QUITTUNG GUT AUF

Die Quittung dient Ihnen als bleibende Unterlage für Ihre wertvolle Anschaffung. Das Aufbewahren der Quittung ist wichtig, da die darin enthaltenen Angaben für Versicherungszwecke oder bei Korrespondenz mit Marantz angeführt werden müssen.

WICHTIG!

Bei Garantieforderungen muß der Kunde eine Kaufunterlage mit Kaufdatum vorlegen. Ihre Quittung oder Rechnung ist als Unterlage ausreichend.

NEDERLANDS

GRANTIE

Voor inlichtingen omtrent garantie dient u zich te wenden tot uw plaatselijke Marantz-handelaar.

UW KWITANTIE, KASSABON E.D. BEWAREN

Uw Kwitantie, kassabon e.d. vormen uw bewijs van aankoop van een waardevol artikel en dienen op een veilige plaats bewaard te worden voor evt. verwijzing, b.v. in verband met verzekering of bij correspondentie met Marantz.

BELANGRIJK

Bij een evt. beroep op de garantie is het de verantwoordelijkheid van de consument een gedateerd bewijs van aankoop te tonen. Uw kassabon of factuur is zijn voldoende bewijs.

ITALIANO

GARANZIA

L'apparecchio è coperto da una garanzia di buon funzionamento della durata di un anno, o del periodo previsto dalla legge, a partire dalla data di acquisto comprovata da un documento attestante il nominativo del Rivenditore e la data di vendita. La garanzia sarà prestata con la sostituzione o la riparazione gratuita delle parti difettose.

Non sono coperti da garanzia difetti derivanti da uso improprio, errata installazione, manutenzione effettuata da personale non autorizzato o, comunque, da circostanze che non possano riferirsi a difetti di funzionamento dell'apparecchio. Sono inoltre esclusi dalla garanzia gli interventi inerenti l'installazione e l'allacciamento agli impianti di alimentazione.

Gli apparecchi verranno riparati presso i nostri Centri di Assistenza Autorizzati. Le spese ed i rischi di trasporto sono a carico del cliente.

La casa costruttrice declina ogni responsabilità per danni diretti o indiretti provocati dalla inosservanza delle prescrizioni di installazione, uso e manutenzione dettagliate nel presente manuale o per guasti dovuti ad uso continuato a fini professionali.

PORTUGUÊS

GARANTIA

Para informações sobre a garantia, contactar o distribuidor Marantz local.

GUARDAR O RECIBO DE COMPRA

O recibo é o registo permanente da compra que fez. Deve ser guardado num local seguro, para ser apresentado em questões relacionadas com o seguro ou para quando tiver de contactar a Marantz.

IMPORTANTE

Quando procurar assistência técnica ao abrigo da garantia, é da responsabilidade do consumidor estabelecer a prova e data de compra. O recibo é prova adequada.

ESPAÑOL

GARANTÍA

Para información sobre las Condiciones de Garantía, sírvase consultar el Certificado que encontrará en el interior del embalaje del equipo.

CONSERVE EL COMPROBANTE DE LA COMPRA

La factura es el comprobante de la adquisición de un producto valioso. Consérvela en lugar seguro para poder consultarla en caso necesario.

IMPORTANTE

Para disponer de servicios cubiertos por la garantía, el usuario deberá acreditar la fecha y el lugar de adquisición del equipo. La factura o recibo de la compra constituyen un comprobante válido a tal efecto.

SVENSKA

GARANTI

Angående garanti, kontakta din lokala Marantz handlare.

SPAR KVITTOT

Kvittot är din Inköpshandling över Inköp av en värdefull vara. Det ska placeras på ett säkert ställe och hänvisas till vid försäkringsfrågor eller vid korrespondens med Marantz.

VIKTIGT

När garantiservice åberopas är det konsumentens ansvar att visa datum för inköp. Ditt kvitto eller din faktura är ett tillfredsställande bevis.

DANSK

GARANTI

Henvend dem til Deres MARANTZ-forhandler angående information om garantien.

GEM DERES KVITTERING

Deres købskvittering er Deres varige bevis på et dyrt køb. Den bør gemmes godt og anvendes som bevis, hvis De vil tegne en forsikring, eller hvis De kommunikerer med Marantz.

VIGTIGT

Det påhviler forbrugeren at skaffe bevis for købet og købsdatoen, hvis han eller hun ønsker garantiservice. Deres købskvittering eller faktura er et fulgyldigt bevis herpå.

CONTENTS LIST

English	page 4
Français	page 17
Deutsch	Seite 30
Nederlands	pagina 43
Italiano	pagina 56
Português	página 69
Español	página 82
Svenska	sidan 95
Dansk	side 108
Specifications	page 121
Figures	page 122

ENGLISH:

CAUTION – USE OF CONTROLS OR ADJUSTMENTS OR PERFORMANCE OF PROCEDURES OTHER THAN THOSE SPECIFIED HEREIN MAY RESULT IN HAZARDOUS RADIATION EXPOSURE.

FINNISH:

VAROITUS! Laitteen käyttäminen muulla kuin tässä käyttöohjeessa mainitulla tavalla saattaa altistaa käyttäjän turvallisuusluokan 1 ylittävälle näkymättömälle lasersäteilylle.

SWEDISH:

VARNING! Om apparaten används på annat sätt än vad som beskrivs i denna bruksanvisning kan användaren utsättas för osynlig laserstrålning som överskrider gränsen för laserklass 1.

WARNINGS FOR LASER RADIATION

CAUTION : INVISIBLE LASER RADIATION WHEN OPEN. DO NOT STARE INTO BEAM.

DANGER : INVISIBLE LASER RADIATION WHEN OPEN. AVOID DIRECT EXPOSURE TO BEAM.

VARO! : AVATTAESSA JA SUOJALUKITUS OHITETTAESSA OLET ALTTIINANAKYMÄTTÖMÄALLE LASERSÄTEILYLLE. ÄLÄ KATSO SÄTEESEEN.

VARNING! : OSYNLIG LASERSTRÅLNING NÄR DENNA DEL ÄR ÖPPNAD OCH SPÄRREN ÄR URKOPPLAD. BETRÄKTA EJ STRALEN.

FOREWORD

This section must be read carefully before any connection is made to the mains supply.

WARNINGS

- Do not expose the equipment to rain or moisture.
- Do not remove the cover from the equipment.
- Do not insert anything into the equipment through the ventilation holes.
- Do not handle the mains lead with wet hands.

CE marking (only /22 version)

CE This product is in conformity with the EMC directive and low-voltage directive.

EQUIPMENT MAINS WORKING SETTING

Your Marantz product complies with the household power and safety requirements in your area.

"/22" Version product can be powered by 230 V AC only.

IMPORTANT: (FOR /65 version only)

This apparatus is fitted with an approved moulded 13 Amp plug. To change a fuse in this type of plug proceed as follows:

1. Remove fuse cover and fuse.
2. Fix new fuse which should be a BS1362 5A, A.S.T.A. or BSI approved type.
3. Refit the fuse cover.

If the fitted plug is not suitable for your socket outlets, it should be cut off and an appropriate plug fitted in its place.

If the mains plug contains a fuse, this should have a value of 5A. If a plug without a fuse is used, the fuse at the distribution board should not be greater than 5A.

NOTE : The severed plug must be destroyed to avoid a possible shock hazard should it be inserted into a 13A socket elsewhere.

HOW TO CONNECT A PLUG

The wires in the mains lead are coloured in accordance with the following code:

BLUE—"NEUTRAL" ("N")

BROWN—"LIVE" ("L")

1. The BLUE wire must be connected to the terminal which is marked with the letter "N" or coloured BLACK.
2. The BROWN wire must be connected to the terminal which is marked with the letter "L" or coloured RED.
3. Do not connect either wires to the earth terminal in the plug which is marked by the letter "E" or by the safety earth symbol \perp or coloured green or green-and-yellow.

Before replacing the plug cover, make certain that the cord grip is clamped over the sheath of the lead — not simply over the two wires.



COPYRIGHT

Recording and playback of some material may require permission. For further information refer to the following:

- Copyright Act 1956
- Dramatic and Musical Performers Act 1958
- Performers Protection Acts 1963, and 1972
- Any subsequent statutory enactments and orders

ABOUT THIS USER'S GUIDE

Refer to the figures on the pages at the back of this user's guide. The callout numbers on the figures correspond to those found in the text.

- Some of the operations described in this user's guide can only be operated from the remote control unit. In the description of controls, the names of the buttons which are available on both the main unit and the remote control unit are enclosed in , and the names of the buttons which are available only on the remote control unit are enclosed in .

PRECAUTIONS

The following precautions should be taken when operating the equipment.

GENERAL PRECAUTIONS

When installing the equipment ensure that:

- the ventilation holes are not covered.
- air is allowed to circulate freely around the equipment.
- it is placed on a vibration-free surface.
- it will not be exposed to excessive heat, cold, moisture or dust.
- it will not be exposed to direct sunlight.
- it will not be exposed to electrostatic discharges.

In addition, never place heavy objects on the equipment.

If a foreign object or water does enter the equipment, contact your nearest dealer or service center.

Do not pull out the plug by pulling on the mains lead; grasp the plug.

It is advisable when leaving the house, or during a thunderstorm, to disconnect the equipment from the mains supply.

FEATURES

- CD-TEXT compatibility.



- CD-RW (ReWritable) playback capability.
- Latest VAM1201 pickup mechanism.
- Digital inputs allowing the unit to be used as a high-performance D/A converter.
- High-performance digital ICs "777 Devices", including the DAC7 1-bit bit stream type D/A converter, the DF7 20-bit, 8-fs digital filter and the CD7 digital servo IC.
- High audio quality parts including the MARANTZ-original HDAM circuitry.
- Highly rigid, stylish design with extensive use of aluminum blocks.
- Stylish wireless remote control unit with aluminum top.

COMPACT DISCS

The glossy side shining like a rainbow is the front side of the disc, and the side on which the label is printed is the back.

Unlike conventional turntables for playing analog discs, the CD-17mkII Compact Disc Player reads the information recorded on the disc from underneath without contacting it using a beam of laser light. Therefore, the performance of a compact disc will not degrade like conventional analog records.

Handle discs carefully so as not to damage or scratch the front side.

To protect the disc, avoid placing it in the following locations:

- In direct sunlight or near a source of heat like a heater.
- In a place which is damp or dirty.
- In a place which could be exposed to rain, such as near a window.

Always keep the disc surface clean.

Up to six billion data units are recorded on the front side of the disc. When cleaning the disc surface, always be sure to use a special compact disc cleaner and wipe as shown below.

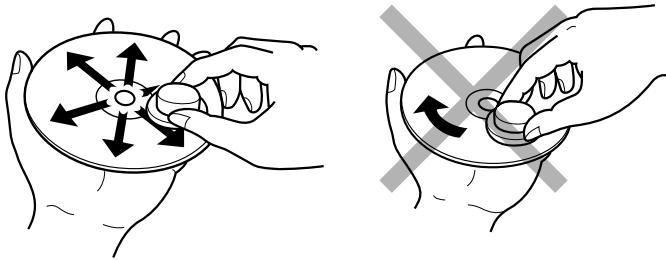

Wipe in a radial direction. Do not wipe in circumferential direction.

- Do not use conventional record cleaner for analog records, as this will adversely affect the disc surface.
Store discs properly by placing them in their disc cases.
- Do not attach a piece of paper or sticker on the label side of disc.
When a disc has a piece of plastic tape or rental CD label with paste protruded from the edge or when a disc has a trace of such a sticky object, do not attempt to play the disc. If such a disc is played on the CD player, impossibility of taking out the disc or other malfunction may result.

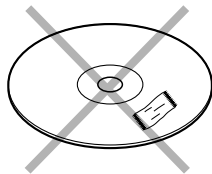

- Do not use a disc with a special shape.
Do not attempt to play a disc with a special shape such as a heart-shaped disc or octagonal disc. Otherwise the equipment malfunction may result.

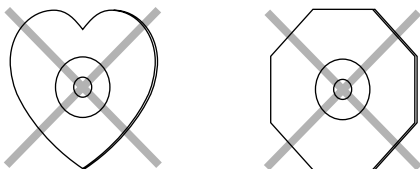

About CD-TEXT

The CD-TEXT is a new type of music CD featuring the recording of character information on the performer names, album name, track names, etc., in addition to the audio information contained in music CD. The character information is recorded in an area which has not been utilized by previous music CDs. This means that the CD-TEXT discs can be played back in the same way as ordinary music CD discs on any CD player and that a CD-TEXT compatible player such as this unit can view the character information in them as well as the audio.

This unit detects the CD-TEXT compatibility of each disc automatically and displays the result in the display panel.

Main unit display

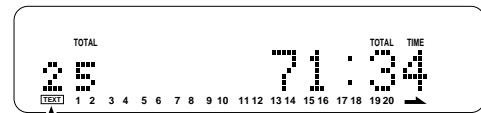

Lights up when the loaded disc is CD-TEXT compatible.

By operating the provided remote control unit, the display can show the character information including the album name, track names, performer names, verse writer names, music composer names, arranger names, message and music genre. However, note that the content of the character information is variable depending on discs.

- * For detailed operating procedures for displaying the character information in the CD-TEXT, read the description in the main text of this manual.

The display of this unit can display up to 12 characters at a time. If the character information in a disc is longer, the characters are scrolled from the left to the right on the display.

- * Scrolling refers to a method of displaying characters by moving them.
This unit is capable of smooth scrolling by feeding characters bit by bit.

Some of the CD-TEXT compatible discs also contains the recording of the highlight sections of its tracks. This unit is capable of playing only the highlight sections one after another, and this feature is referred to as HIGHLIGHT SCAN.

Playing CD-RW discs

This unit can play back the CD-RW (ReWritable) discs as well as ordinary music CD and CD-R (Recordable) discs.

- * The CD-R and CD-RW discs should contain properly-recorded TOC information so that they can be played back. With the CD recorder system, writing the TOC information in a disc is referred to as finalizing the disc. A disc cannot be recognized as a CD disc and played back unless it has been finalized properly. For details, please read the instruction manual provided with a CD recorder.
- * TOC stands for Table Of Contents and contains information such as the total number of tracks and total playing time of the disc.
- * This unit can play only the discs recorded in the CD-DA format designed for music reproduction. Do not attempt to play a disc containing other data, such as a CD-ROM for PCs, on this unit.
- * As the playback of a CD-RW disc necessitates partial change of the player setup, it may take longer time for reading the TOC information than when a music CD or CD-R disc is played.

CONTROLS, CONNECTIONS AND INDICATORS

Please read the following instructions referring to the illustration on page 122.

FRONT

1 POWER switch

Press to switch power ON, and press again to switch OFF.

2 DISC TRAY

Place a disc with the label side up.

3 Display

Shows information such as the power ON/OFF state, track number, playing time and current operation mode.

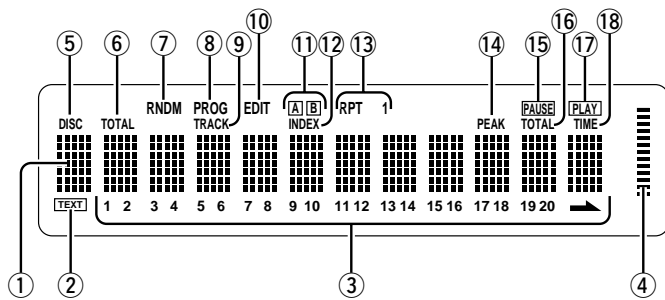

1 TIME/TEXT information

Shows the time information when an ordinary music CD is played, and shows the text information when a CD-TEXT compatible disc is played.

2 TEXT CD-TEXT indicator

Lights up when a CD-TEXT compatible disc is loaded.

3 Track number indicator

When a disc is placed on the tray and the tray is closed, the TOC* is read and the numbers of all the tracks on the disc are displayed "►" lights up if there are more than 20 tracks on the disc. In program mode only the track numbers of the programmed tracks light up.

The track numbers go out in turn as each track finishes playing.
* TOC is the disc's "Table Of Contents" and contains non-audio data such as the track numbers and playing times of all the tracks on the disc.

4 Output level indicator

Shows the analog output level as a relative reference.

5 DISC indicator

Blinks during TOC readout.

6 TOTAL indicator

Lights up when the total number of tracks in a disc is displayed.

7 RNDM (Random) indicator

Lights up in the random play mode.

8 PROG (Program) indicator

Lights up in the programming or delete programming mode.

9 TRACK indicator

Lights up when the track number being played is displayed.

10 EDIT indicator

Lights up when the player is in edit mode.

11 A/B indicators

Both indicators light up in the A-B repeat mode or one of them lights up during playback of tape side A or B in the edit mode.

12 INDEX indicator

Lights up when the index number being played is displayed.

13 RPT (Repeat) indicators

RPT: Lights up during all-track repeat mode, which plays all the tracks on the disc repeatedly. Also lights up during program repeat mode, which plays all the programmed tracks repeatedly.
RPT 1: Lights up during 1-track repeat mode, which repeatedly plays a single track repeatedly.

14 PEAK indicator

Lights up during peak search, and flashes during playback of the peak.

15 PAUSE indicator

Light up in the pause mode.

16 TOTAL indicator

Indicates the remaining playing time of the entire disc. In program mode, this indicator shows the remaining playing of the current program.

17 PLAY indicator

Light up during CD playback.

18 TIME indicator

Lights up in the time display mode.

4 ▲ OPEN/CLOSE button

Pressing the ▲ OPEN/CLOSE button opens the disc tray. Place a compact disc on the tray with the label side facing up. Gently press the front of the disc tray to close.

5 REMOTE SENSOR

This window receives signals transmitted from the remote control unit.

6 ► PLAY button

Press to start playback.

7 ■ STOP button

Press to stop playback. This button is also used for deleting a program.

8 || PAUSE button

Press to interrupt playback temporarily. The indicator lights up during pause. When pressed again, the indicator goes out and playback resumes from the same position.

9 ◀◀, ▶▶ (Track Previous/Next) buttons

When the ◀◀ button is pressed during playback, play re-starts at the beginning of the current or a previous track. When the ▶▶ button is pressed, play re-starts at the beginning of the next or a subsequent track. The same number of tracks as the number of times the button is pressed can be skipped.

The selected track number is shown on the display.

These buttons can also be used to select a desired track from which to start playback.

These buttons are also used in program mode to select tracks for programming.

REAR

A ANALOG OUTPUT jacks

Connect to the CD or AUX input jacks of a preamplifier.

B DIGITAL OUTPUT OPTICAL output jack

The digital signal can be transmitted in the form of light through an optical fiber cable and photocoupler. The optical signal transmission features low signal loss due to cables and complete isolation of the ground loop so that the very high quality can be reproduced without any digital noise.

Connection method:

Connect this jack to a D/A converter, digital sound processor or an amplifier equipped with a Digital Optical input jack. Remove the caps from the DIGITAL OUTPUT OPTICAL jack and the Optical input jack of the connected component and connect the two jacks through an optical fiber cable.

* Do not bend the optical fiber cable.

* Leave the cap attached when the OPTICAL jack is not used.

C DIGITAL OUTPUT COAXIAL output jack

By connecting this jack to a digital audio component (D/A converter, digital sound processor, etc.), digital signals from compact discs can be transmitted directly from the player without first being converted to analog.

D REMOTE CONTROL IN/OUT jacks

By connecting this CD player to another Marantz audio component using a D-BUS remote control cable, you can operate the components remotely as a single system.

- When connecting to a component with a remote sensor, connect the REMOTE CONTROL IN jack of this unit to the REMOTE CONTROL OUT jack of the component with the remote sensor.
- When connecting to a component which is not equipped with a remote sensor, connect the component to the REMOTE CONTROL OUT jack of this unit.

For the D-BUS cable connection, use a commercially available RCA-type pin lead.

- By connecting this CD player to a Marantz auto reverse cassette deck (such as the SD-555), automatic recording from the CD player to the cassette deck can be carried out.

E REMOTE switch

When using this unit independently, set this switch to INTERNAL. When using this unit in a system incorporating a Marantz tuner or timer equipped with a remote sensor, set the switch to EXTERNAL.

NOTE

Always set this switch to INTERNAL unless the unit is connected with other MARANTZ equipment through a system connection. When this switch is set to EXTERNAL, the main unit cannot be controlled from the provided remote control unit.

F AC POWER INPUT jack

Using the provided AC cord, connect to a household AC power outlet.

USING THE REMOTE CONTROL UNIT

1. Remote control

Operate the remote control unit (RC-Da17CD) within a distance of approx. 5 m from the infrared signal reception window (remote sensor) on the front of the CD player.

Remote control operation may not be possible if the remote control unit's transmitter is not pointing in the direction of the remote sensor or if there is an obstruction between the transmitter and the remote sensor.

Remote control operating range

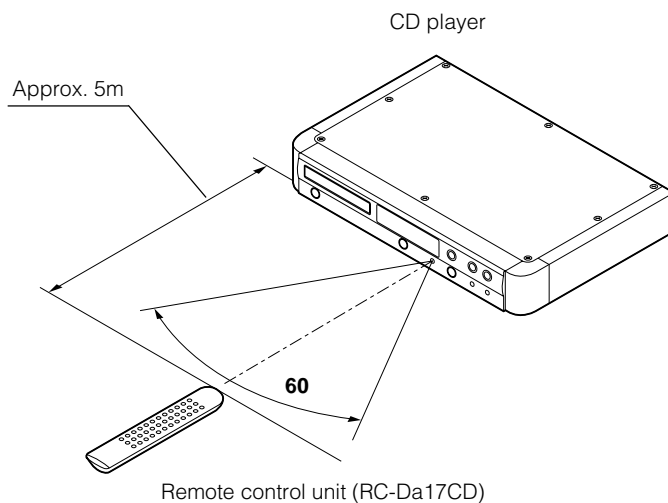

2. Loading batteries

Batteries in this remote control unit have a life of approximately 1 year under normal operating conditions. If the remote control unit is not going to be used for an extended period of time, remove the batteries. Also, if you notice that the batteries are starting to run down, replace them as soon as possible.

① Remove the battery cover.

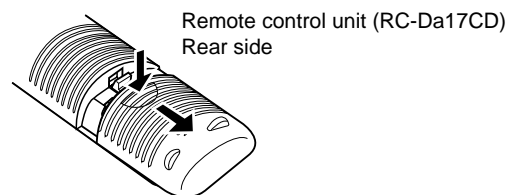

② Insert the batteries with correct +/- orientation.

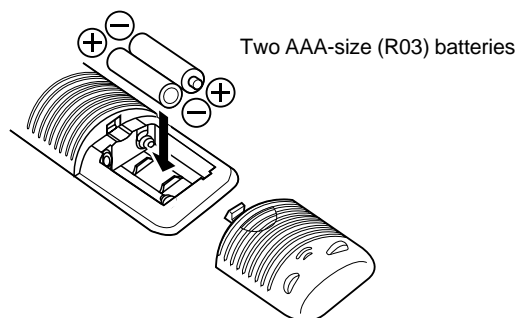

③ Close the battery cover until it clicks shut.

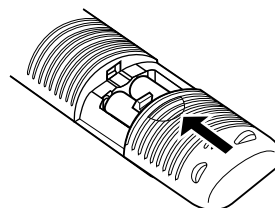

REMOTE CONTROL UNIT RC-Da17CD

When the power to the CD player is ON and a disc is loaded on the disc tray, the remote control unit (RC-Da17CD) can be used to operate the player's various functions. However, the power to the CD player must be switched ON/OFF using the POWER switch on the main unit.

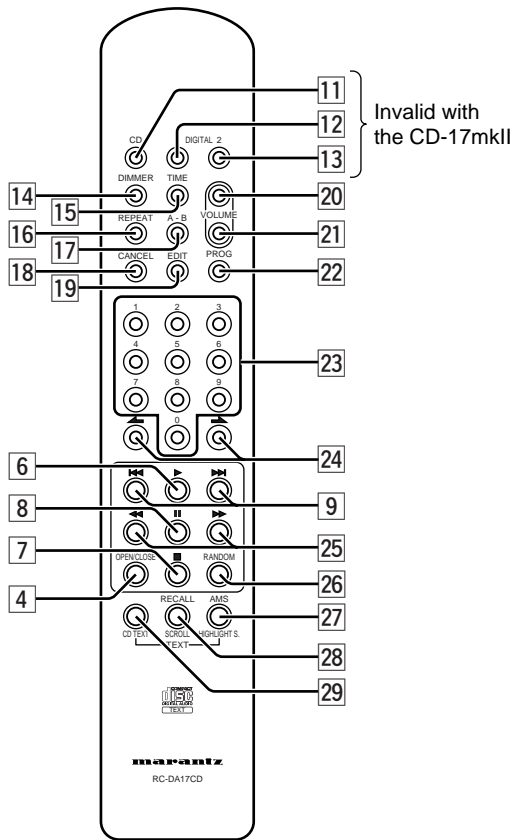

4 ▲ OPEN/CLOSE button

6 ► PLAY button

7 ■ STOP button

8 || PAUSE button

9 ◀▶, ▶▶ buttons

These buttons have the same functions as the buttons with the same names on the main unit front panel. See the corresponding descriptions on page 6.

11 CD button

With the CD-17mkII, this button is invalid.

12, 13 DIGITAL 1, 2 button

With the CD-17mkII, this button is invalid.

14 DIMMER button

Press to adjust the display illumination brightness. The illumination at its the brightest when the power is switched ON. Each time this button is pressed, the brightness dim until the fourth press, after which the illumination returns to the original brightness.

15 TIME button

Switches the time shown on the display to the remaining time of the current track or the remaining time of the entire disc. With a CD-TEXT disc, this switch is also used to switch the displayed information from the text display mode to the time display mode.

16 REPEAT button

Press to select 1-track repeat, all-track repeat or program repeat playback mode.

17 A-B button

Used to set the starting and stopping points of a passage for repeated playback.

18 CANCEL button

Used to delete specified track numbers from a program. Also used when creating programs by deleting any tracks which you do not want to listen to (delete programming).

19 EDIT button

Press to engage the editing function, which helps record a disc onto a tape by playing the tracks according to the tape length and leaving a non-recorded blank of 4 seconds between every track.

20 VOL(▲), 21 VOL(▼) buttons

Press to vary the ANALOG OUTPUT volume between 0 and -30 dB. The level when the power is turned on is 0 dB (maximum volume).

22 PROG button

Press to activate program play, so that only the selected tracks from the disc loaded on the disc tray will be played.

23 Numeric (0 to 9) buttons

When used during playback, these buttons allow you to specify the number of another track you want to play. When used during stop mode, these buttons allow you to specify the number of a track from which to start playback. These buttons are also used to select tracks for programming.

24 INDEX buttons

- ▶ : Press during playback to advance to the next index.
- ◀ : Press during playback to return to the next index.

* These buttons are valid when playing a disc in which index have been recorded.

25 ◀◀, ▶▶ (Search Reverse/Forward) buttons

- ◀◀ : When pressed during playback, this button fast-reverses the play position.
- ▶▶ : When pressed during playback, this button fast-forwards the play position.

26 RANDOM button

When this button is pressed, the player enters random play mode (tracks on the disc are selected and played in a random order). When pressed again, random play is cancelled.

27 AMS (Automatic Music Scan)/HIGHLIGHT S.(Highlight Scan) button

When this button is pressed, the player automatically plays the first 10-second part of each track in the disc. If the loaded disc is a CD-TEXT disc containing the highlight information, the first press of the button initiates the Highlight Scan operation and the second press initiates the normal AMS operation as described above.

28 RECALL/SCROLL button

Press this button to display the programmed track numbers and program numbers (the order the tracks are programmed) in sequence. If the loaded disc is a CD-TEXT disc, press this button while the text information is displayed to scroll the characters.

29 CD-TEXT button

When playing a CD-TEXT disc, press this button to switch the time display to the text information display.

* If this button is pressed when the loaded disc is not a CD-TEXT compatible disc, the display shows "No Text" then returns to the time display.

Normal playback operation

CD player playback

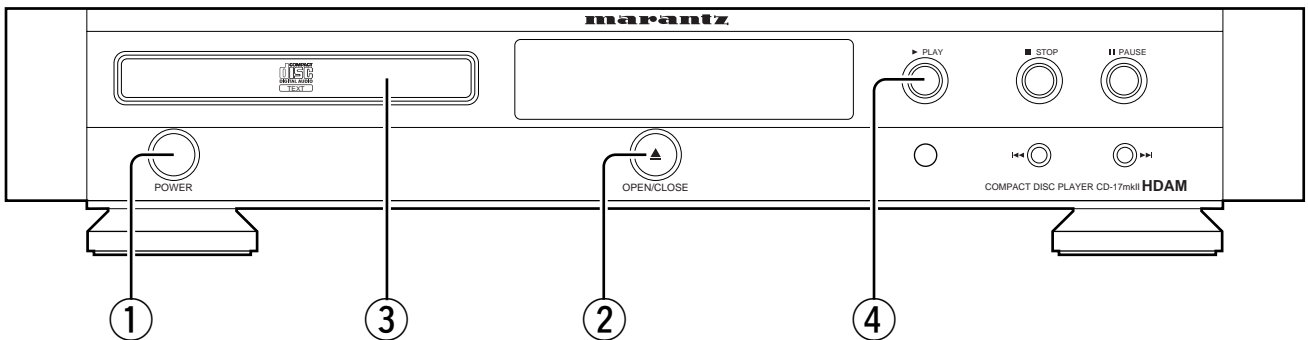

- ① Press the **POWER** switch to turn on the power.

Display indications

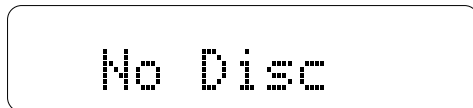

- ② Press the **OPEN/CLOSE** button.

When the disc tray opens, place a disc on the tray with the label side up.

- ③ Gently press the front of the disc tray or press the **OPEN/CLOSE** button to close the tray.

- ④ Press the **PLAY** button.

When the button is pressed, the **PLAY** indicator lights up.

While the disc is playing, the display shows the track number and elapsed playing time of the track currently playing, along with the numbers of the tracks still to be played or playing.

To stop playback:

Press the **STOP** button.

To remove the disc:

Open the disc tray by pressing the **OPEN/CLOSE** button, remove the disc, then close the tray by lightly pressing its front edge. Always keep the disc tray closed even when the CD player is not being used.

To pause playback:

Press the **PAUSE** button.

The PAUSE indicator lights up and playback pauses at the position where the button was pressed. To resume playback from the pause position, press the **PAUSE** button again.

To switch the time display:

Press the **TIME** button.

Each time the **TIME** button is pressed, the time display changes in the following order: Elapsed playing time of the currently playing track t_1 Remaining playing time of the current track t_2 Total remaining time in the disc t_3 Elapsed playing time of the current track.

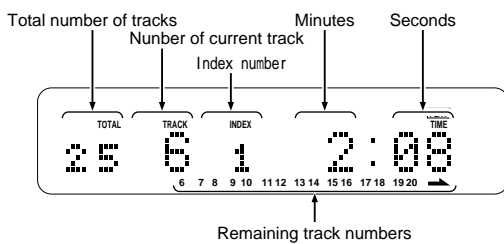

SEARCHING/SKIPPING

Direct search (specifying a desired track number)

Specify the track number using numeric buttons 0 to 9.

For track number 3, press **(3)**.

For track number 12, press **(1)**, then, within 1.5 seconds, press **(2)**.

If the first of two digits pressed is not one of the digits on the CD, it is interpreted as 1 digit and the search will start after about 0.5 second.

If you make a mistake when pressing the numeric buttons:

Press the right buttons to enter the correct track number.

- If you specify a track number which does not exist on the disc, "No Track" will appear on the display. Enter the correct number.



Track Skip

If the loaded disc is a CD-TEXT disc and the display is presently in the text display mode, press the **(TIME)** button to switch it to the time display mode.

Next (skipping to a desired track located after the currently playing track)

Press the **(▶▶)** button the necessary number of times to skip to the desired track.

Previous (skipping to a desired track located after the currently playing track)

To skip to the previous track to the current track, press the **(◀◀)** button twice. To skip to a track located before the previous track, press the **(◀◀◀)** button for the necessary number of times to skip to the desired track.

- Pressing the **(◀◀)** button twice in the middle of the first track in a disc skips to the last track, and pressing the **(▶▶)** button in the middle of the last track skips to the first track.

Index Skip (⏪ ⏩)

This is a convenient function which allows to search the desired index during playback of a track with indexes recorded in it (see the description of the INDEX buttons on page 8).

- When an index number that does not exist in the disc selected, the display shows "No Index" and playback restarts from the beginning of the original index.

AMS (Listening to the first part of each track)

1. Press the **(AMS/HIGHLIGHT S)** button during stop or playback.

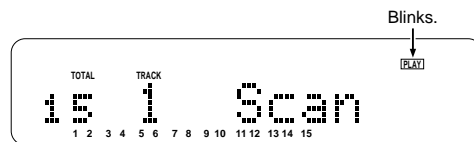

The first part (first 10 seconds) of each track in the disc will be played in the order in which the tracks are recorded.

2. When you find a track you want to listen to, press the **(AMS/HIGHLIGHT S)** button again. (The PLAY indicator stops blinking and starts to light steadily.)

- If the **(◀◀)** or **(▶▶)** button is pressed during AMS operation, the CD player increases or decreases the played track number for the same number of times as the number of times the button was pressed, but the AMS operation is not canceled.

Highlight Scan

When the loaded disc is a CD-TEXT disc containing the recording of highlight information, pressing the **(AMS/HIGHLIGHT S)** button initiates the Highlight Scan operation in precedence over the AMS operation.

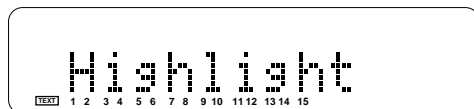

Pressing the **(AMS/HIGHLIGHT S)** button during Highlight Scan initiates the AMS operation.

REPEAT PLAY

1-track repeat (repeated playback of one track only)

While the track you want to repeat is playing, press the **(REPEAT)** button twice.

The "RPT" and "1" indicators light up and the current track will be played repeatedly.

To cancel 1-track repeat play:

Press the **(REPEAT)** button once.

All-track repeat (repeated playback of all tracks on the disc)

During playback, press the **(REPEAT)** button once.

The "RPT" indicator lights up and all the tracks on the disc are played repeatedly.

Even if the **(REPEAT)** button is pressed in stop mode, playback will start and repeat playback will be carried out.

To resume normal playback:

Press the **(REPEAT)** button twice. The "RPT" indicator goes out, repeat mode is cancelled and normal playback resumes.

A-B repeat (repeated playback of a specified passage)

1. During playback, press the remote control unit's **(A-B)** button at the starting point of the passage you want to repeat. "A" (starting point) indicator lights up.

2. Press the **(A-B)** button again at the end of the passage you want to repeat. "B" (stopping point) indicator lights up. The designated passage A-B will be played repeatedly.

To cancel A-B repeat play:

Press the **(A-B)** button. The "A" and "B" indicator goes out, A-B repeat is cancelled and normal playback resumes.

RANDOM PLAY

In this mode, the CD player automatically selects and plays tracks in random order. All tracks are played once. Press the **(RANDOM)** button.

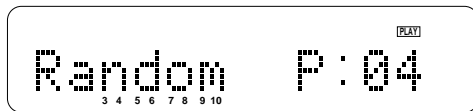

Random playback begins in about 4 seconds.

- During random playback, tracks are separated by an interval of about 4 seconds.
- The **(RANDOM)** button can be pressed either during playback or in stop mode. If the **(RANDOM)** button is pressed while the disc tray is open with a disc on the tray, the disc tray automatically closes and random playback begins.
- To stop random playback and resume normal playback: Press the **(RANDOM)** button again.
- If the **(SKIP)** button is pressed during random playback: Each time one of these buttons is pressed, the CD player selects a track at random and starts playing that track.
- If the **(REVERSE)** or **(PLAY)** button is pressed during random playback: Searching is carried out within the current track. The search operation will not cross over into the previous or next track.
- To repeatedly play tracks at random: Press the **(REPEAT)** button once. All tracks are repeatedly played in random order, with the order being changed each time the disc is played.

NOTE

- A-B repeat playback is not available during random playback.
- When the **(RANDOM)** button is pressed after the programming operation (page 11) or delete programming operation (page 12), random playback of the tracks selected with the programming or delete programming operation starts.

PROGRAM PLAY

Programming (To play the desired tracks in a certain order)

Programming when the display is in the time display mode

If the loaded disc is a CD-TEXT disc, press the **(TIME)** button to switch it to the time display mode.

(Example: To program track No. 15 first, then track No. 7 in a 15-track disc)

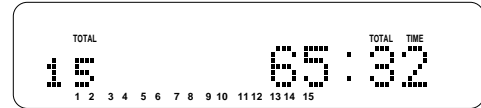

1. Press the **(PROG)** button in stop mode. The PROG indicator flashes.

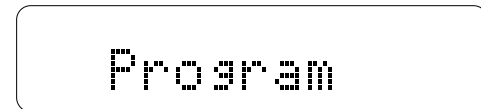

Flashes.



2. Specify the first track to be programmed using the numeric buttons or the **(SKIP)** or **(REVERSE)** button.

(Display example: The first programmed track is track number 15 with a playing time of 4 minutes 30 seconds)

Flashes.

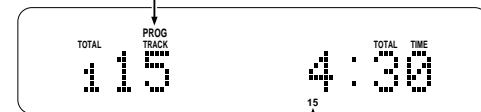

Only the numbers of programmed tracks light up.

3. Then program another track by repeating the procedure in step 2 above. Up to 30 tracks can be programmed in this way.

(Display example: The second programmed track is track No. 7 and the total playing time of track Nos. 15 and 7 is 7 minutes 50 seconds.)



Total programmed tracks
Last programmed track
Total playing time of programmed tracks

4. After having programmed all the desired tracks, press the **(PROG)** button or **(STOP)** button.

The PROG indicator status changes from flashing to continuously lit, indicating that the program is completed.

Light up continuously



5. Press the **(PLAY)** button, The programmed tracks will be played in the programmed order.

Programming when the display is in the text display mode

If the loaded disc is a CD-TEXT disc, tracks can also be programmed by referring to the track titles.

If the display is not in the text display mode, press the **CD-TEXT** button to put it to the text display mode.

(Example: To program track Nos. 15 and 7)

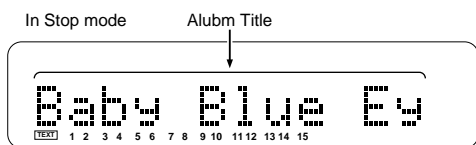

1. Press the **PROG.** button in stop mode. The PROG indicator flashes.

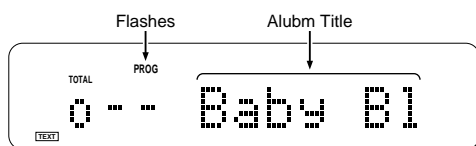
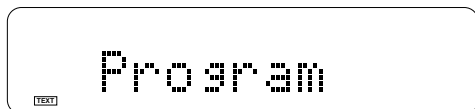

2. Specify the first track to be programmed using the numeric buttons or the **▶▶** or **◀◀** button.

The track title of the selected track scrolls. In about 1 second after the completion of scrolling, the track is automatically programmed. If you do not want to program the track, select another track using the numeric buttons or the **▶▶** or **◀◀** button before the automatic programming takes place.

(Display example: The first programmed track is track No. 15 with a track title of "Phoenix".)

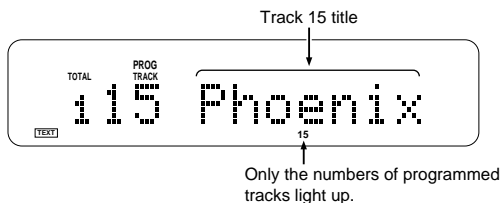

3. Then program another track by repeating the procedure in step 2 above.

(Display example: The second programmed track is track No. 7 with a track title of "Moonlig..".)

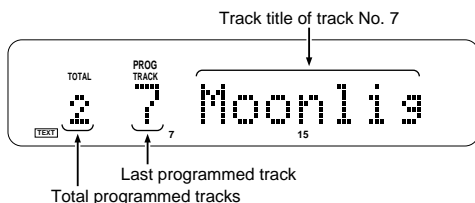

4. After having programmed all the desired tracks, press the **PROG.** button or **STOP** button.

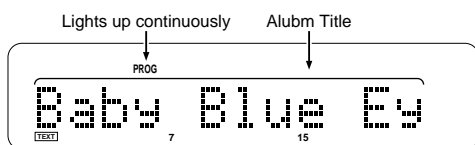

5. Press the **▶PLAY** button, The programmed tracks will be played in the programmed order.

Delete programming (Listening only to the desired tracks by omitting unwanted tracks)

- Ordinary music CD: Delete programming is possible only when the display is in the time display mode.
- CD-TEXT disc: Delete programming is possible whether the display is in the time display mode or text display mode.

Delete programming when the display is in the time display mode

If the loaded disc is a CD-TEXT disc, press the **TIME** button to switch it to the time display mode.

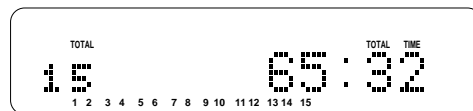

(Example: To program the tracks on a 15-track disc with the exception of track numbers 3 and 7)

1. Press the **PROG.** button in stop mode and, when the PROG indicator starts to flash, press the **CANCEL** button. The total number of tracks and total playing time of the disc will be displayed.

(Display example: The total playing time is 65 minutes 32 seconds)

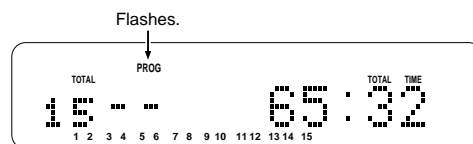
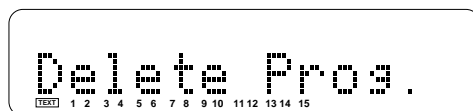

2. Select the unwanted tracks using the numeric buttons or the **▶▶** or **◀◀** button. Up to 30 tracks can be selected and omitted in this way.

(Display example: Track No. 12 is selected first and the total playing time of the remaining tracks is 60 minutes 12 seconds.)

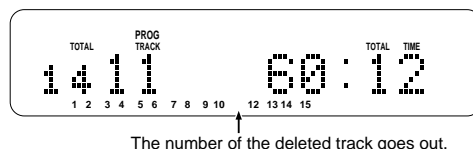

3. After having selected and deleted all of the unwanted tracks, press the **PROG.** button or **STOP** button. The PROG indicator status changes from flashing to continuously lit, indicating that the program is completed.

(Display example: The total playing time of the 12 tracks, omitting track numbers 3, 7 and 11, is 51 minutes 22 seconds)

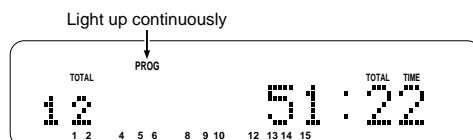

4. Press the **▶PLAY** button, The tracks except for the deleted tracks will be played in the order of the track numbers.

Delete programming when the display is in the text display mode

If the loaded disc is a CD-TEXT disc, tracks can also be omitted by referring to the track titles.

If the display is not in the text display mode, press the **(CD-TEXT)** button to put it to the text display mode.

(Example: To omit track Nos. 11 and 7)

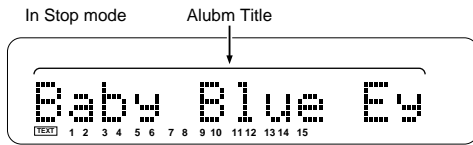

1. Press the **(PROG.)** button in stop mode and, when the PROG indicator starts to flash, press the **(CANCEL)** button. The total number of tracks and album title of the disc will be displayed.

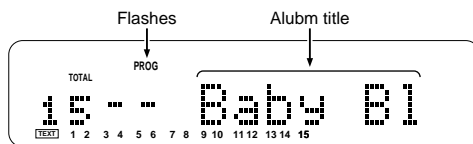
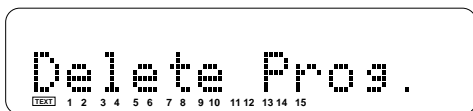

2. Select the unwanted tracks using the numeric buttons or the **(▶▶)** or **(◀◀)** button.

The track title of the selected track scrolls. In about 1 second after the completion of scrolling, the track is automatically omitted. If you do not want to omit the track, select another track using the numeric buttons or the **(▶▶)** or **(◀◀)** button before completion of the scrolling. Up to 30 tracks can be omitted in this way.

(Display example: The first selected track to be omitted is track No. 11 with a track title of "Graduat...".)

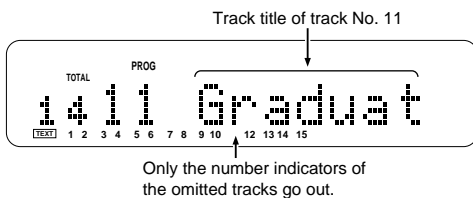

- By selecting a previously selected and omitted track again during delete programming, the delete programming operation can be suspended temporarily.

3. After having selected and deleted all of the unwanted tracks, press the **(PROG.)** button or **(STOP)** button.

The PROG indicator status changes from flashing to continuously lit, indicating that the program is completed.

(Display example: The total 12 tracks, omitting track numbers 3, 7 and 11 and album title of disc.)

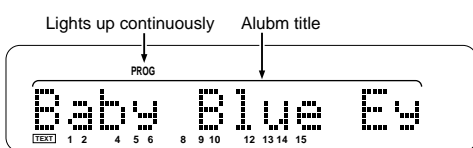

4. Press the **(▶▶)** button, The tracks except for the deleted tracks will be played in the order of the track numbers.

NOTES

- * Take note of the following points when programming tracks by programming or delete programming.
- * When selecting track numbers 1 to 9 using numeric buttons from a disc containing 10 or more tracks (when selecting track number 3 after track number 2, for example), press 3 more than 1.5 seconds after pressing 2.
- * When using numeric buttons to select track number 10 or higher on a disc containing 10 or more tracks (for example when selecting track number 13), press 3 within 1.5 seconds of pressing 1.
- * When using numeric buttons to select track numbers on a disc containing no more than 9 tracks (when selecting track number 5 after track number 4, for example), press 5 more than about 0.5 second after pressing 4.
- * When programming track numbers using the **(▶▶)** and **(◀◀)** buttons, press buttons with intervals of less than 1 second.

To check the programmed contents:

Press the **(RECALL/SCROLL)** button during programming or program playback.

If it is pressed during "programming", the programmed track numbers will be displayed sequentially in the order they have been programmed. If it is pressed during "delete programming", the deleted track numbers will be displayed.

To erase some of the programmed tracks:

1. Press the **(RECALL/SCROLL)** button to display the programmed track numbers sequentially in the order in which they have been programmed.
2. When the track number to be erased from the program is displayed, press the **(CANCEL)** button immediately.

The track number indicator of the track erased from the program goes out.

To re-incorporate in the program a track which has been deleted in "delete programming":

1. Press the **(RECALL/SCROLL)** button during delete programming to display the deleted track numbers sequentially in the order in which they were deleted.
2. When the track number to be added to the program is displayed, press the **(CANCEL)** button immediately.

The track number indicator of the track added to the program lights up.

To erase the entire program:

During program playback, press the **(STOP)** button twice. In stop mode, press the **(STOP)** button once.

- The program is also erased by pressing the **(▲OPEN/CLOSE)** button to open the disc tray.

To add tracks to the program:

In stop mode with the program stored in the memory (that is, with the PROG indicator lit up), press the **(PROG.)** button. The PROG indicator starts flashing and more tracks can be added to the program.

Q&A

- **How many tracks is it possible to program?**
Up to 30 tracks can be included in the program. With delete programming, up to 30 tracks can be omitted from the program.
- **Is it possible to change from programming to delete programming or vice versa?**
No.
- **How do you play programmed tracks repeatedly?**
Press the **(REPEAT)** button once. The REPEAT indicator lights up and the program playback will be repeated.
- **How do you play programmed tracks in a random order?**
Press the **(RANDOM)** button during program playback or in stop mode.
- **The display cannot be switched between the time display and text display modes during programming or delete programming.**
Be always sure to select either display mode before starting the programming or delete programming operation.

EDITING

When recording from a compact disc to a tape, use this function to match the tape length to the playing time of the tracks to be recorded and to create 4-second intervals between the tracks.

Auto peak level search

If the cassette deck recording level is adjusted in relation to the peak level on the disc, it is possible to avoid distortion and noise in recording. This facility allows the peak over the entire disc or in the programmed to be detected tracks before proceeding to editing.

Simple edit

This operation fits tracks into a specified tape length while keeping the tracks in their original order.

1. Press the **EDIT** button in stop mode to light up the EDIT indicator. (Example: When a disc with 28 tracks is loaded)

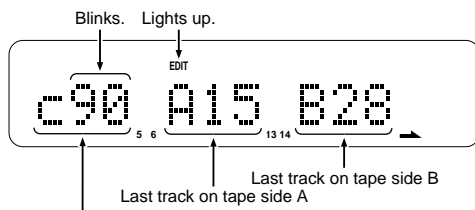
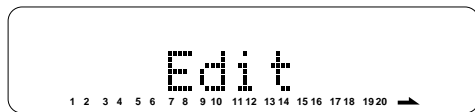

The tape recording time display (90) appears.

This example shows that, when the tape recording time is 90 minutes, track 15 is the last track on tape side A and track 28 the last track on tape side B. In other words, by using a 90-minute tape, all of the 28 disc tracks can be accommodated by assigning tracks 1 to 15 on tape side A and tracks 16 to 28 on tape side B.

2. To change the tape recording time, specify the new tape recording time using the numeric buttons (0 to 9) or the **▶▶** or **◀◀** button.

- When numeric buttons are used to specify a C-46 tape, for example, press **4** then **6**.

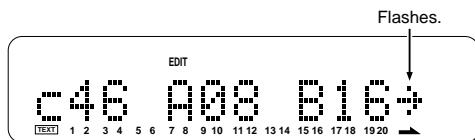

This display example shows that, with a 46-minute tape, tracks 1 to 8 will be recorded onto tape side A and tracks 9 to 16 will be recorded onto tape side B.

The blinking arrow on the right end of the character display shows that tracks 17 and after cannot be recorded on the tape.

- Use of **▶▶** and **◀◀** buttons

Each press of the **▶▶** button allows you to change the recording time in the order 90 fi 46 fi 54 fi 60 fi 74 fi 90.

Each press of the **◀◀** button allows you to change the recording time in the order 90 fi 74 fi 60 fi 54 fi 46 fi 90.

Each press of the **▶▶** button allows you to increase the recording time by 1 minute.

Each press of the **◀◀** button allows to decrease the recording time by 1 minute.

3. Press the **▶PLAY** button. The PEAK indicator lights up and the auto peak level search operation starts from track number 1.

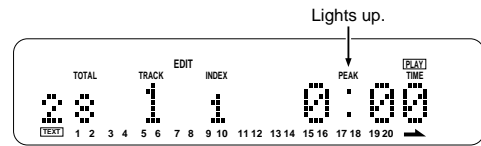

4. After the auto peak level search of the last track has finished, the passage of about 6 seconds centered around the peak position will be played 4 times. Adjust the recording level of the cassette deck during this period. For the adjustment procedure, refer to the instruction manual supplied with your cassette deck.

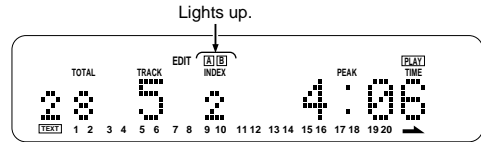

5. After the peak passage has been played 4 times, the CD player enters pause mode to stand by for the edit play of tape side A.

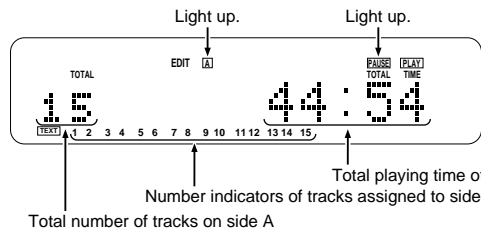

6. Press the **||PAUSE** button to start edit play for tape side A.

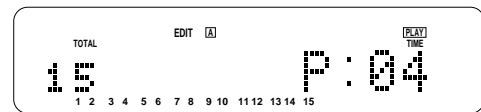

7. After edit play for tape side A has been completed, the CD player automatically enters pause mode to standby for the edit play of tape side B.

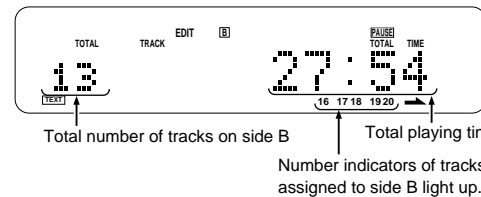

8. To start edit play for side B, press the **||PAUSE** button.

Program edit

This procedure allows you to record tracks in any desired order while fitting the tracks into a specified tape length.

1. Program tracks according to the programming procedure in section "PROGRAM PLAY" (page 11).
2. The rest of the program edit procedure is the same as step 1 to 8 in the simple edit procedure.

Delete program edit

When recording from a disc to a tape, this procedure allows you to omit the tracks you do not want to record, while fitting the tracks into a specified tape length.

1. Program tracks according to the "delete programming" procedure in the "PROGRAM PLAY" section (page 12).
2. The rest of the delete program edit procedure is the same as step 1 to 8 in the simple edit procedure.

NOTES

- As a CD may contain several peaks, a different peak may be found every time the auto peak level search operation is performed.
- During simple edit play, program edit play and delete program edit play operations other than the STOP, OPEN/CLOSE, DIMMER, VOLUME, RECALL and TIME control operations are defeated. This is intended to prevent mistakes in recording due to erroneous operation.
- The display is always in the time display mode during edit play. It is not possible to switch to the text display mode.
- If you want to skip the auto peak level search:
In step 3 of the simple edit procedure, press the **▶PLAY** button again. The PAUSE indicator lights up and the CD player enters the pause mode. When the **⏸PAUSE** button is pressed later on, the edit play for tape side A will start immediately, without the auto peak level search operation.

Synchro Recording

This function starts the recording of the cassette deck automatically in synchronism with the start of edit play of the CD player.

- Synchro recording can be started only when a Marantz autoreverse cassette deck (ex. SD-555 etc.) with synchro recording compatibility is connected to the CD player.
 - Synchro recording is performed through the remote line connection (rear panel jacks).
1. Set up the cassette deck for synchro recording. For the detailed operations, please refer to the User Guide of the cassette deck.
 2. When the pause button of the CD player is pressed to start the edit play for tape side A, the cassette deck also starts automatically.

NOTE

When a tape with shorter length than the set tape recording time, the CD player stops playback of tracks assigned for tape side A at the moment recording of side A has completed. When recording of tape side B starts, the CD player also starts playback of the tracks assigned for side B.

CD-TEXT information display

The text information on CD-TEXT discs is displayed in the order shown below each time the CD-TEXT button on the remote control unit is pressed. However that the included information differs from disc to disc, so not all this information will necessarily be displayed. With this set, items for which no text information is recorded on the disc are automatically skipped.

The displayed text can be scrolled by pressing the **(RECALL/SCROLL)** button.

- During playback

The displayed information switches in the order below each time the **(CD-TEXT)** button is pressed. During playback, most of the displayed information is for the currently playing track.

→	Title of currently playing track	
	f1	
	Album Title	(album title)
	f1	
	xx Title	(title of track number xx)
	f1	
	xx Artist	(artist of track number xx)
	f1	
	xx Songwriter	(songwriter of track number xx)
	f1	
	xx Composer	(composer of track number xx)
	f1	
	xx Arranger	(arranger of track number xx)
	f1	
	xx Message	(message for track number xx)
	f1	
	Disc ID	(album identification number)
	f1	
	Genre	(album's music category)
	f1	
←	xx Info. End	(end of information for track number xx)

- In the stop mode

The displayed information switches in the order below each time the **(CD-TEXT)** button is pressed.

→	Album Title	
	f1	
	Album Title	(album title)
	f1	
	-- Title	(title of -- track)
	f1	
	Artist	(album's artist)
	f1	
	-- Artist	(artist of -- track)
	f1	
	Songwriter	(album's songwriter)
	f1	
	-- Songwriter	(songwriter of -- track)
	f1	
	Composer	(album's composer)
	f1	
	-- Composer	(composer of -- track)
	f1	
	Arranger	(album's arranger)
	f1	
	-- Arranger	(arranger of -- track)
	f1	
	Message	(album's message)
	f1	
	-- Message	(message for -- track)
	f1	
	Disc ID	(album identification number)
	f1	
	Genre	(album's music category)
	f1	
←	All Info. End	(end of all text information)

TROUBLE SHOOTING

If you think a malfunction has occurred, first check the points listed below. The problem is likely to have been caused by a simple operational error or a connection problem. If the problem cannot be corrected even after carrying out the following checks, consult your dealer or nearest Marantz sales office or service counter.

- **The disc fails to rotate.**
 1. Is the mains lead plugged in properly?
 2. Is the POWER switch ON?
 3. Is the disc placed in the correct position on the disc tray?
 4. Is the disc placed properly with the label side facing up?
 5. Is the disc dirty?
 6. Is the disc scratched?
 7. Is the disc warped?
- **The disc is rotating but no sound is heard.**
 1. Are the amplifier and speakers connected properly?
 2. Is the amplifier switch ON?
 3. Is the amplifier's volume control set at the minimum level?
 4. Is the amplifier's selector switch set to the correct input ("CD" or "AUX", whichever corresponds to the input jacks the CD player is connected to)?
- **The disc stops in mid-operation.**
 1. Is the disc dirty?
 2. Is the disc scratched?
 3. Is the disc warped?
- **The sound drops out or noise is heard.**
 1. Is the disc dirty?
 2. Is the disc scratched?
 3. Is the disc warped?
- **Remote control operation is not possible.**
 1. Is the remote control unit's transmitter pointed correctly at the remote sensor on the front of the CD player?
Or is there an obstruction between the transmitter and the remote sensor?
 2. Are the batteries in the remote control unit exhausted?
 3. Is there another strong light (from a window, etc.) striking the CD player's remote sensor?
 4. Is an RCA-type pin-plug lead connected to the "REMOTE CONTROL IN" jack on the CD player's rear panel?
- **A CD-R/CD-RW disc cannot be played.**
 1. Is the disc placed upside down?
 2. Is the disc contains properly written TOC?

OPERATING PRECAUTIONS

- In the winter you may notice that condensation forms on the window of a well-heated room.
Condensation may also occur inside the CD player in the following situations:
 - When the listening room is first heated.
 - When the humidity in the room is high.
 - When the unit is moved from a cold environment to a warm room.
- If condensation occurs, the number of tracks cannot be read and the CD player may not function properly. If this happens, leave the power ON and wait for about 30 minutes before operating the unit.
- The CD player may interfere with the reception of your tuner or TV set. If this occurs, place the CD player farther away from the tuner or TV.
- The CD player features very little noise compared to analog records, and the noise before actual playback begins is almost inaudible. Therefore, be careful not to set the volume control of the amplifier too high, otherwise other audio components such as the speakers may be damaged when actual playback starts.

CLEANING OF EXTERIOR SURFACES

With proper care and cleaning, the exterior finish of your equipment will last indefinitely. Never use scouring pads, steel wool, scouring powders or harsh chemical agents (e.g. lye solution), alcohol, thinners, benzene, insecticide or other volatile substances, as these will mar the finish of the cabinet. Likewise, never use cloths containing chemical substances. If the equipment becomes dirty, wipe the external surfaces with a soft, lint-free cloth.

If the cabinet becomes heavily soiled:

- dilute some washing-up liquid in water, in a ratio of one part detergent to six parts water;
- dip a soft, lint-free cloth in the solution and wring the cloth out until it is damp;
- wipe the equipment with the damp cloth;
- dry the equipment by wiping it with a dry cloth.

REPAIRS

Only the most competent and qualified service technicians should be allowed to service the equipment. The Marantz company and its factory-trained warranty station personnel have the knowledge and special facilities needed for the repair and calibration of this precision equipment. After the warranty period has expired, repairs will be performed for a charge if the equipment can be restored to normal operation.

In the event of difficulty, consult your dealer or write directly to the nearest location to you that is listed on the Marantz Authorized Service Station list. Please quote the model and serial number of the equipment and give a full description of what you think is abnormal about the equipment's behaviour.

MODEL CD-17mkII TECHNICAL SPECIFICATIONS

Audio Characteristics

Channels	2 channels
Sampling frequency	44.1 kHz
Quantization	16-bit linear/channel
Error correction	Cross-interleave read solomon code (CIRC)
D/A conversion	1-bit linear/channel
Wow & flutter	Precision of quartz

Optical Readout System

Laser	GaAlAs semiconductor
Wavelength	780 nm

Frequency Characteristics

Frequency range	5Hz-20kHz
Dynamic range	> 98 dB
S/N ratio (WTD)	> 103 dB
Channel separation (1 kHz)	>100 dB
THD (1 kHz)	0.0015 %
Analog output	
Output level (cinch JACKS)	2.2 V RMS
Output impededance	250 ohms
Digital output	
output level (cinch JACK)	0.5 Vp-p/75 ohms
output level (optical)	-19 dBm

Power Supply

/22 version	230 V AC 50 Hz
Power Consumption	19 W

Cabinet, etc.

Dimensions	
Width	458 mm
Height	83 mm
Depth	313 mm
Net weight	7.8 kg
Operating temperatures	+5 °C ~ +35 °C
Operating humidity	5 % ~ 90 % (without dew)

Accessories

Remote control unit (RC-Da17CD)	1
AAA (R03) Batteries	2
Stereo audio cable with cinch pins	1 pair
Remote cable with cinch pins	1
AC Power Cord	1

Specifications subject to change without prior notice.

Model CD-17mkII

FRONT VIEW

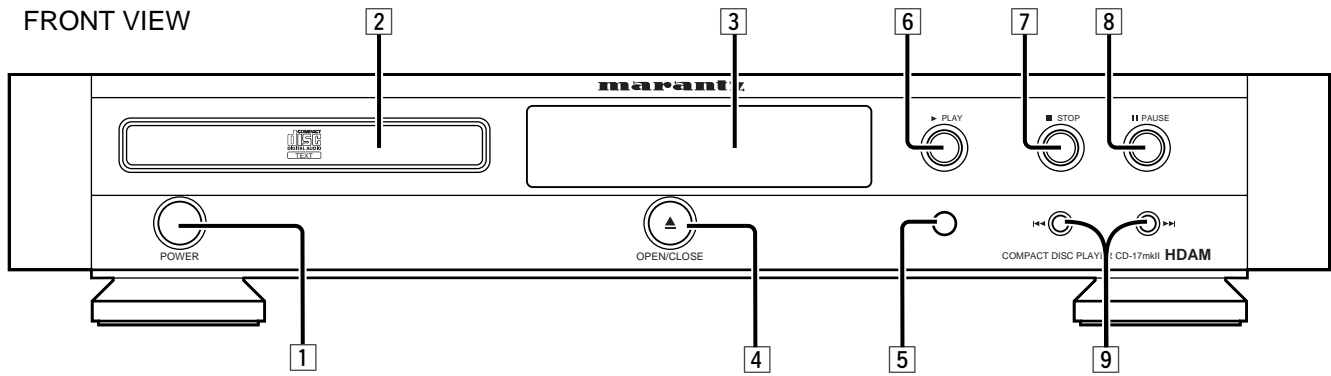

REAR VIEW

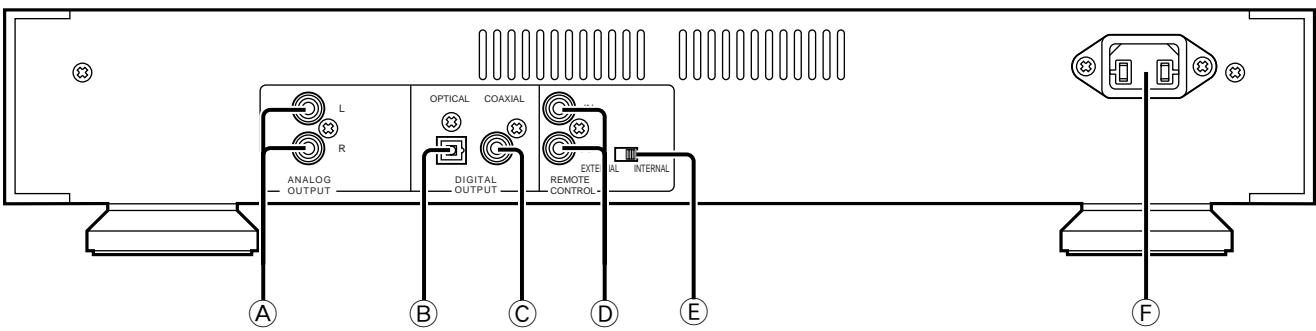

COUNTRY	COMPANY	ADDRESS
ALGERIE	Azur 2000	8, Lotissement Ben Hatadi, Alger, Algerie
ARMENIA	NGYIG Ltd.	47 A/75 St. Lalaianst, 375000 Yerevan, Armenia
AUSTRALIA	Jamo Australia Pty. Ltd.,	24 Lionel Road, Mt. Waverley, VIC 3149, Australia
AUSTRIA	Huber & Prohaska GmbH	Taborstraße 95 / Ladestraße 1, Gebäude Hangartner, A-1200 Wien, Austria
BAHREIN	Ambassador Stores	P.O. Box 237,141, Government Avenue, Manama,Bahrein
BANGLADESH	Target	1078, Ramjoy Mohanja Lane Asadgonj, Chittagong 4000, Bangladesh
BELGIUM	Van der Heyden Audio N.V.	Brusselbaan 278, 9320 Erembodegem, Belgium
BULGARIA	Ariescommerce GmbH	Makedonia Blvd. 16, 1606 Sofia, Bulgaria
CANADA	Lenbrook Industries Limited	633 Granite Court, Pickering, Ontario
CHINA	Guang Chang Audio International Co., Ltd.	No.38 Yushan Road, ShiQiao, Pan Yu, Guang Dong, China
CYPRUS	Empire Hifi systems Ltd.	P.O. Box 5604, Nicosia, Cyprus
CZECH REPUBLIC	Audio International	Sokolska 41, 67902 Rajecsko, OKR,Blansko, Czech Republic
DENMARK	Audio Nord	Dali Allé 1, 9610 Noerager, Denmark
DUBAI	V.V.& SONS	P.O. Box 105, Dubai, U.A.E.
EGYPT	Solimco	9, El Attibaa St. Doki, Cairo, Egypt
ESTONIA	HiFi Club Estonia	Ehte 4, 90503 Haapsalu, Estonia
F.Y.R.O.M.	T.P. KODI	ul.Cedomir Kantargiev 21a, Skopje, Former Yugoslavian Republic of Macedonia
FINLAND	Audio Nord	Uudenmaankatu 4-6, Helsinki SF-00120, Finland
FRANCE	Marantz France	A division of Marantz Europe B.V., P.O. Box 301, 92 156 Suresnes Cedex, France
GERMANY	Marantz Deutschland	Hakenbusch 3, 49078 Osnabrück, Germany
GREECE	Adamco S.A.	188, Hippocratous Street, 11471 Athens, Greece
HEADQUARTERS EUROPE:	Marantz Europe B.V.	Building SFF-2, P.O. Box 80002, 5600 JB Eindhoven, The Netherlands
HONG KONG	Marantz Asia Ltd.	Unit 1706, Metroplaza II, 223 Hing Fong Road, Kwai Fong, N.T., Kowloon, Hong Kong
HUNGARY	Infovox Ltd.	Terez Krt.31, 1067 Budapest, Hungary
ICELAND	ID Electronics Ltd.	Armula 38, 108 Reykjavik, Iceland
INDIA	NOVA Audio Private	8,Punam Co-op.Society 29/30 Road#5, Union Park MUMBAI 400052, India
IRAN	Home Co.	5th floor no 878 Philips Building Enghelab ave, P.O. 11365/7844 Tehran, Iran
IRELAND	Marantz Ireland	Clonskeagh, Dublin 14, Ireland
ISRAEL	Elmor Ltd.	52 Heh Beiyar Street, Kikar Hamedina, Tel Aviv, Israel
ITALY	Marantz Italy	Via Casati 23, 20052 Monza (Milano), Italy, Servizio Consumatori 1678-20026, Numero Verde
IVORY COAST	Hifivoir	B.P. 2428, Abidjan 01, Ivory Coast
JAPAN	Marantz Japan Inc.	35-1 Sagami Ohno 7-Chome, Sagamihara-shi, Kanagawa 228-8505, Japan
KOREA	Mk Enterprises Ltd.	121-210, 2F Shinhan Bldg., 247-17 Seokyo-dong, Mapo-ku, Seoul, Korea
KUWAIT	alAlamiah Electronics Intl.	P.O. Box 8196, Salmiah 22052, Kuwait
LATVIA	Ace Ltd.	61, LacPlesa Str., Riga LV 1011, Latvia
LEBANON	AZ Electronics S.A., 1,	P.O. Box 11 2833, Beirut, Lebanon
LITHUANIA	Accapella Ltd.	Ausros, Vartu G/5, Pasazo SKG., 2001 Vilnius, Lithuania
MALAYSIA	Wo Kee Hong Electronics Sdn. Bhd.	Suite 8.1, Level 8, Menara Genesis, No. 33, Jalan Sultan Ismail, 50250 Kuala Lumpur, Malaysia
MALTA	Doneo Co Ltd.	78 The Strand, Sliema SLM07, Malta
MAURITIUS	SKR Electronics Ltd.	P.O. Box 685, Bell Village, Port Louis, Mauritius
MILITARY MARKET EUROPE	PASCO GmbH	PO BOX 1280, Sandhausen 69200, Germany
NETHERLANDS	Marantz Domestic Sales	A division of Marantz Europe B.V., Building SFF2, P.O. Box 80002, 5600 JB Eindhoven, The Netherlands
NEW ZEALAND	Wildash Audio Systems	14 Malvern Road, Mt. Albert, Auckland, New Zealand
NORWAY	Audio Nord	Sandkerveien 64, Oslo 0483, Norway
OMAN	Mustafa & Jawad Trading CO.	P.O. Box 1918, Ruwi, Oman
POLAND	Philips Polska Sp. z.o.o.	Al.Jerozolimskie 195b, 02 222 Warszawa, Poland
PORTUGAL	Corel2	Comércio de Electrónica Lda., Av. Luis Bivar, No 85 A, 1050 Lisboa, Portugal
PROFESSIONAL EUROPE	Marantz Professional Products	Kingsbridge House, Padbury Oaks, 575-583 Bath Road, Longford, Middlesex UB7 0EH, U.K.
PROFESSIONAL U.S.A.	Marantz Professional Products	Distributed by: Superscope Technologies Inc., 1000 Corporate Blvd. Ste.D, Aurora, Illinois
QATAR	Almana & Partners W.W.L.	P.O. Box 49, Doha, Qatar
REUNION	Vision +	180 Rue du Marechal Leclerc, 97400 Saint Denis, Ile de la Reunion
ROMANIA	Nova Music Entertainment	5, Zagazului Str. Bl.1G,apt.18, sector 1,Bucharest, Romania
RUSSIA	Absolute Audio	7/2, Montazhnaya Street, 107497 Moscow, Russia
SAUDI ARABIA	Adawlia Univ. Electr. Apl	P.O. Box 2154, Alkhobar 31952, Saudi Arabia
SINGAPORE	Wo Kee Hong Distribution PTE Ltd.	130 Joo Seng Road, #03-02 Olivine Building, Singapore 368357
SLOVAKIA	Bis Audio s.r.o.	Nam. SNP 10, 96001 Zvolem, Slovakia
SLOVENIA	Bofex	Smartinska 152, HALA V/3, 61000 Ljubljana, Slovenia
SOUTH AFRICA	Coherent Imports (PTY) Ltd.	P.O. Box 1614, Alberton, 1450, South Africa
SPAIN	Marantz Spain	Martinez Villergas 2, Apartado 2065, Madrid 28027, Spain
SRI LANKA	The listening Room	Mezzanine Floor, The Landmark 385, Galle Road, Colombo - 3, Sri Lanka
SWEDEN	Audio Nord	Almedalsvagen 4, Gotenborg 402-23, Sweden
SWITZERLAND	Sound Company AG	Postfach, 8010 Zürich, Switzerland
SYRIA	Hamzeh & Partners	Hafez Ibrahim Str. No 117, Damascus Shalan, Syria
TAHITI	Covecolor	Av. Prince Hinoi, Cours de l'union sacré, P.O. Box 2334, Papeete, Tahiti
TAIWAN	Pai-Yuing Co. Ltd.	6th No 148 Sung Kiang Road, Taipei 10429, Taiwan R.O.C.
THAILAND	MRZ Standard Co. Ltd.	746-750 Mahachai Road, Wangburapa, Bangkok 10200, Thailand
TUNESIA	Societe EDEVIG	40, Avenue du Golfe Arabe, El Menzah, 1004, Tunesia
TURKEY	Türk Philips Ticaret A.S.	Yukari Dudullu Organize sanayi Bolgesi, 2.Cadde no.28, 81260 Umraniye-Istanbul, Turkey
U.K.	Marantz Hifi UK Ltd.	Kingsbridge House, Padbury Oaks, 575-583 Bath Road, Longford, Middlesex UB7 0EH, U.K.
U.S.A.	Marantz America Inc.	1100 Maplewood Drive Itasca, IL 60143, U.S.A.
YUGOSLAVIA	ITM Company	Omladinskih Brigada 86, 11070 Belgrade, Yugoslavia
EXPORT	Marantz Domestic Sales	A division of Marantz Europe BV,Building SFF2, P.O. Box 80002, 5600 JB Eindhoven, TheThe Netherlands

www.marantz.com

marantz® is a registered trademark.

